

Prüfbericht-Nr.: <i>Test report no.:</i>	CN22805C 001	Auftrags-Nr.: <i>Order no.:</i>	168330663	Seite 1 von 15 <i>Page 1 of 15</i>
Kunden-Referenz-Nr.: <i>Client reference no.:</i>	N/A	Auftragsdatum: <i>Order date:</i>	2021-08-11	
Auftraggeber: <i>Client:</i>	Autel Intelligent Automobile Corp., Ltd. Room 701, Building B1, Zhiyuan, No.1001 Xueyuan Avenue, Changyuan Community, Taoyuan Road, Nanshan District, Shenzhen, 518055, China			
Prüfgegenstand: <i>Test item:</i>	ASR100			
Bezeichnung / Typ-Nr.: <i>Identification / Type no.:</i>	ASR100, ASR100-XXX-XX (X = A-Z or a-z or 0-9) (Trade Name: Autel)			
Auftrags-Inhalt: <i>Order content:</i>	Test Report			
Prüfgrundlage: <i>Test specification:</i>	FCC CFR Title 47, Part 95, Subpart M KDB 653005 D01 76-81 GHz Radars v01r01 FCC CFR Title 47, Part 2, Subpart J, Section 2.1091			
Wareneingangsdatum: <i>Date of sample receipt:</i>	2022-01-07	Please refer to Photo Document		
Prüfmuster-Nr.: <i>Test sample no.:</i>	A003186910-004			
Prüfzeitraum: <i>Testing period:</i>	2022-03-01 to 2022-03-08			
Ort der Prüfung: <i>Place of testing:</i>	TÜV Rheinland Taiwan Ltd.			
Prüflaboratorium: <i>Testing laboratory:</i>	TÜV Rheinland (Shenzhen) Co., Ltd.			
Prüfergebnis*: <i>Test result*:</i>	Pass			
geprüft von: <i>tested by:</i>	 Hardy Suo	genehmigt von: <i>authorized by:</i>	 Lin Lin	
Datum: <i>Date:</i>	2022-04-02	Ausstellungsdatum: <i>Issue date:</i>	2022-04-02	
Stellung / Position:	Sachverständige(r)/Expert	Stellung / Position:	Sachverständige(r)/Expert	
Sonstiges / Other:	FCC ID: 2A56MASR100-001			
Zustand des Prüfgegenstandes bei Anlieferung: <i>Condition of the test item at delivery:</i>	Prüfmuster vollständig und unbeschädigt <i>Test item complete and undamaged</i>			
* Legende:	1 = sehr gut	2 = gut	3 = befriedigend	4 = ausreichend
	5 = mangelhaft	P(ass) = entspricht o.g. Prüfgrundlage(n)	F(ail) = entspricht nicht o.g. Prüfgrundlage(n)	N/A = nicht anwendbar
	N/T = nicht getestet	* Legend:	1 = very good	2 = good
	3 = satisfactory	4 = sufficient	5 = poor	P(ass) = passed a.m. test specification(s)
	F(ail) = failed a.m. test specification(s)	N/A = not applicable	N/T = not tested	
Dieser Prüfbericht bezieht sich nur auf das o.g. Prüfmuster und darf ohne Genehmigung der Prüfstelle nicht auszugsweise vervielfältigt werden. Dieser Bericht berechtigt nicht zur Verwendung eines Prüfzeichens. <i>This test report only relates to the a. m. test sample. Without permission of the test center this test report is not permitted to be duplicated in extracts. This test report does not entitle to carry any test mark.</i>				

V05

Test Summary

5.1.1 OCCUPIED BANDWIDTH

RESULT: Pass

5.1.2 RADIATED E.I.R.P. POWER

RESULT: Pass

5.1.3 UNWANTED EMISSIONS

RESULT: Pass

5.1.4 FREQUENCY STABILITY

RESULT: Pass

6.1.1 ELECTROMAGNETIC FIELDS

RESULT: Pass

Table of Contents

1	GENERAL REMARKS	4
1.1	COMPLEMENTARY MATERIALS	4
2	TEST SITES	5
2.1	TEST FACILITIES	5
2.2	LIST OF TEST AND MEASUREMENT INSTRUMENTS.....	5
2.3	TRACEABILITY	6
2.4	CALIBRATION	6
2.5	MEASUREMENT UNCERTAINTY.....	6
2.6	LOCATION OF ORIGINAL DATA.....	6
2.7	STATUS OF FACILITY USED FOR TESTING.....	6
3	GENERAL PRODUCT INFORMATION	7
3.1	PRODUCT FUNCTION AND INTENDED USE.....	7
3.2	RATINGS AND SYSTEM DETAILS	7
3.3	INDEPENDENT OPERATION MODES	7
3.4	NOISE GENERATING AND NOISE SUPPRESSING PARTS.....	7
3.5	SUBMITTED DOCUMENTS.....	7
4	TEST SET-UP AND OPERATION MODES	8
4.1	PRINCIPLE OF CONFIGURATION SELECTION	8
4.2	TEST OPERATION AND TEST SOFTWARE.....	8
4.3	SPECIAL ACCESSORIES AND AUXILIARY EQUIPMENT.....	8
4.4	COUNTERMEASURES TO ACHIEVE EMC COMPLIANCE.....	8
4.5	TEST SETUP DIAGRAM.....	9
5	TEST RESULTS	10
5.1	TRANSMITTER REQUIREMENT & TEST SUITES	10
5.1.1	<i>Occupied Bandwidth</i>	<i>10</i>
5.1.2	<i>Radiated E.I.R.P. Power</i>	<i>11</i>
5.1.3	<i>Unwanted emissions</i>	<i>12</i>
5.1.4	<i>Frequency stability</i>	<i>13</i>
6	SAFETY HUMAN EXPOSURE	14
6.1	RADIO FREQUENCY EXPOSURE COMPLIANCE	14
6.1.1	<i>Electromagnetic Fields.....</i>	<i>14</i>
7	PHOTOGRAPHS OF THE TEST SET-UP.....	15
8	LIST OF TABLES.....	15

1 General Remarks

1.1 Complementary Materials

All attachments are integral parts of this test report. This applies especially to the following appendix:

Appendix A: Photographs of the Test Set-up

Appendix B: Test Results

2 Test Sites

2.1 Test Facilities

TÜV Rheinland Taiwan Ltd.

No. 458-19, Sec. 2, Fenliao Rd., Linkou District, New Taipei City, Taiwan

FCC Designation number: TW1135

2.2 List of Test and Measurement Instruments

Table 1 List of Test and Measurement Equipment

Kind of Equipment	Manufacturer	Model No.	Serial No.	Calibrated Date	Next Calibrated Date
Receiver	R&S	ESR7	102109	2021/3/16	2022/3/15
Signal Analyzer	R&S	FSV40	101508	2021/3/16	2022/3/15
Bilog Antenna	SCHWARZBECK	VULB-9168	00949	2021/3/30	2022/3/29
Horn Antenna	ETS-Lindgren	3117	00218930	2021/12/20	2022/12/19
Horn Antenna	SCHWARZBECK	BBHA 9170	00887	2021/4/8	2022/4/7
LF-AMP	Agilent	8447D	2727A05146	2022/2/16	2023/2/15
HF-AMP + AC source	EMCI	EMC051845SE	980633	2022/2/16	2023/2/15
HF-AMP + AC source	EMCI	EMC184045SE	980657	2022/2/16	2023/2/15
Microwave Cable	HUBER+SUHNER	SUCOFLEX 104EA	800056/4EA	2021/3/17	2022/3/16
Microwave Cable	HUBER+SUHNER	SUCOFLEX 104	804680/4	2021/3/17	2022/3/16
Microwave Cable	HUBER+SUHNER	SUCOFLEX 104	MY37202/4	2021/3/17	2022/3/16
Microwave Cable	HUBER+SUHNER	SUCOFLEX 102EA	800898/2EA	2021/4/16	2022/4/15
Microwave Cable	HUBER+SUHNER	SUCOFLEX 102EA	800901/2EA	2021/4/16	2024/4/15
Microwave Cable	HUBER+SUHNER	SUCOFLEX 102EA	801027/2EA	2021/4/16	2024/4/15
Loop Antenna	SCHWARZBECK	FMZB1519B	00215	2021/12/8	2024/12/7
Mixer SA	VDI	N9029AV15	SAX 039	2019/7/1	2022/6/30
Mixer SA	VDI	N9029AV12	SAX 243	2019/7/1	2022/6/30
Mixer SA	VDI	N9029AV10	SAX 047	2019/7/1	2022/6/30
Mixer SA	VDI	N9029AV08	SAX 045	2019/7/1	2022/6/30
Mixer SA	VDI	N9029AV05	SAX 044	2019/7/1	2022/6/30
Mixer SA	VDI	N9029AV03	SAX 295	2019/7/1	2022/6/30
Harmonic Mixer	Keysight	M1971W	MY56390137	2019/7/1	2022/6/30
Harmonic Mixer	Keysight	M19HWDX	160118-1	2020/12/8	2023/12/8
Signal Analyzer	Agilent	N9010A	MY52221334	2021/3/4	2024/3/3

2.3 Traceability

All measurement equipment calibrations are traceable to NIM (National Institute of Metrology) or where calibration is performed in other countries, to equivalent nationally recognized standards organizations.

2.4 Calibration

Equipment requiring calibration is calibrated periodically by the manufacturer or according to manufacturer's specifications. Additionally all equipment is verified for proper performance on a regular basis using in house standards or comparisons.

2.5 Measurement Uncertainty

The estimated combined standard uncertainty for radiated emissions and conducted emissions measurements as below table.

Parameter	Uncertainty
Radio frequency	$\pm 1 \times 10^{-7}$
Radiated RF power (up to 40 GHz)	± 1.38 dB
Radiated RF power (above 40 GHz up to 75 GHz)	± 2.86 dB
Radiated RF power (above 75 GHz up to 110 GHz)	± 1.72 dB
Radiated RF power (above 110 GHz up to 140 GHz)	± 1.84 dB
Radiated RF power (above 140 GHz up to 220 GHz)	± 2.41 dB
Temperature	± 1 °C
Humidity	± 5 %

2.6 Location of Original Data

The original copies of all test data taken during actual testing were attached at Appendix A & B of this report and delivered to the applicant. A copy has been retained in the TÜV Rheinland (Shenzhen) Co., Ltd. file for certification follow-up purposes.

2.7 Status of Facility Used for Testing

The TÜV Rheinland Taiwan Ltd. Test facility located at No. 458-19, Sec. 2, Fenliao Rd., Linkou District, New Taipei City, Taiwan is listed on the US Federal Communications Commission list of facilities approved to perform measurements.

3 General Product Information

3.1 Product Function and Intended Use

The EUT is a Short Range Radar use in the vehicle, which that operation frequency range is 76GHz to 77GHz.

For details refer to the User Manual, Technical Description and Circuit Diagram.

3.2 Ratings and System Details

Table 2: Technical Specification of EUT

General Information of EUT	Value
Kind of Equipment:	ASR100
Type Designation:	ASR100, ASR100-XXX-XX (X = A-Z or a-z or 0-9)
Trade Name:	Autel
Operating Voltage:	12Vdc, 24Vdc (battery operated)
Technical Specification of EUT	Value
Assigned Band:	76GHz to 77GHz
Operation Frequency Range:	76GHz to 77GHz
Operation Frequency Bandwidth:	1GHz
Operating Temperature Range:	-40 °C ~ 85 °C
Type of Modulation:	FMCW
Antenna Type:	Array patch antenna
Antenna Gain:	TX: Maximum 10.7dBi RX: Maximum 8.2dBi
Remark: Models ASR100 and ASR100, ASR100-XXX-XX (X = A-Z or a-z or 0-9) are identical in PCBA, drivers and enclosure, the only difference is installation position and software version that will be not impact the compliance as declared by Autel.	

3.3 Independent Operation Modes

The basic operation modes are:

- A. Tx mode
- B. Off

3.4 Noise Generating and Noise Suppressing Parts

Refer to Circuit Diagram for further details.

3.5 Submitted Documents

- Application Form

- Rating Label

- Block Diagram

- Operation Description

4 Test Set-up and Operation Modes

4.1 Principle of Configuration Selection

Radio Spectrum: The equipment under test (EUT) was configured at its highest power output in order to measure its highest possible radiation and conducted level. The test modes were adapted accordingly in reference to the instructions for use.

Emission: The equipment under test (EUT) was configured to measure its highest possible radiation level. The test modes were adapted accordingly in reference to the instructions for use.

4.2 Test Operation and Test Software

Test operation refers to test setup in chapter 5. All tests were performed according to the procedures in ANSI C63.26: 2015 & ANSI C63.10: 2020.

Test operation refers to test setup in chapter 5, 12Vdc and 24Vdc configurations were tested and the worst case recorded in this report.

4.3 Special Accessories and Auxiliary Equipment

Table 3: Auxiliary Equipment Used during Test

Description	Brand	Model	S/N	Remark
DC Power Supply	GWINSTEK	GPS-3303	GEU915613	Provided by Lab
Notebook	Lenovo	20150	CB21920765	Provided by Lab
DC Cable	Autel	--	--	Length 810 cm, provided by Autel
Sensor	Autel	--	--	Length 291 cm, provided by Autel

4.4 Countermeasures to Achieve EMC Compliance

The test sample which has been tested contained the noise suppression parts as described in the Technical Construction File (TCF).

No additional measures were employed to achieve compliance.

4.5 Test Setup Diagram

Diagram of Measurement Configuration for Radiation Test (Below 30MHz)

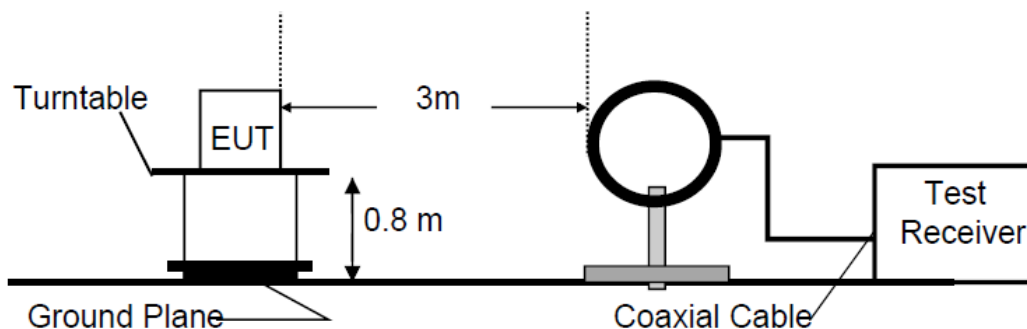

Diagram of Measurement Configuration for Radiation Test (Below 1GHz)

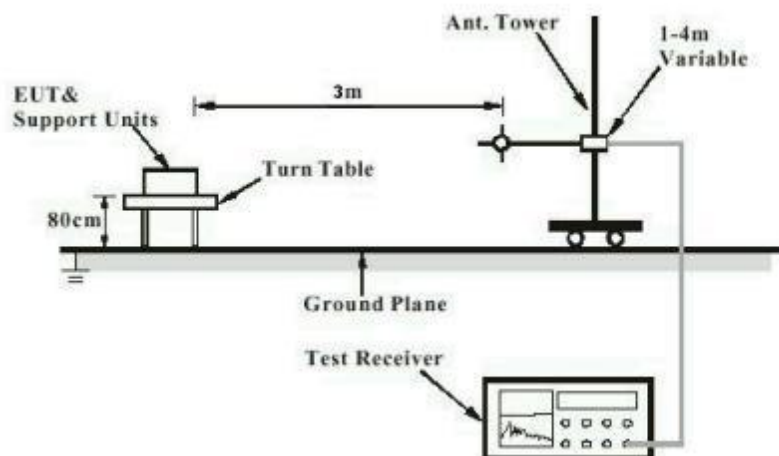
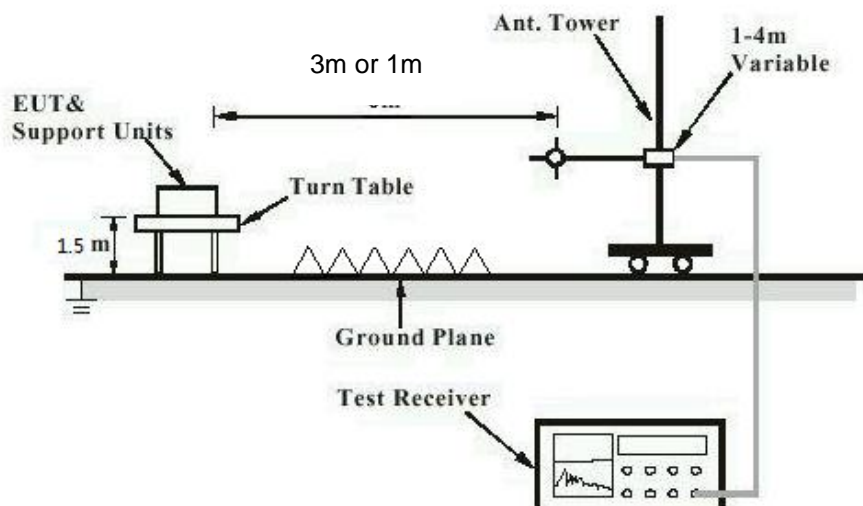

Diagram of Measurement Configuration for Radiation Test (Above 1GHz)



5 Test Results

5.1 Transmitter Requirement & Test Suites

5.1.1 Occupied Bandwidth

RESULT:

Pass

Test Specification

Test standard	:	FCC Part 2.1049
	:	FCC Part 95.3379 (b)
Basic standard	:	ANSI C63.26: 2015, Clause 5.4
Limits	:	Within assigned band (76GHz to 81GHz)
Kind of test site	:	3m Full-anechoic Chamber

Test Setup

Date of testing	:	2022-03-01 to 2022-03-08
Input voltage	:	24Vdc
Operation mode	:	A
Ambient temperature	:	24.5~26.5 °C
Relative humidity	:	50~53 %
Atmospheric pressure	:	100~103 kPa

For the measurement records, refer to the appendix B.

5.1.2 Radiated E.I.R.P. Power

RESULT:**Pass****Test Specification**

Test standard	: FCC Part 95.3367
Basic standard	: ANSI C63.26: 2015, Clause 5.2 : ANSI C63.10: 2020, Clause 9
Limits	: FCC Part 95.3367 (a), Average E.I.R.P. ≤50dBm/MHz : FCC Part 95.3367 (b), Peak E.I.R.P. ≤55dBm/MHz
Kind of test site	: 3m Full-anechoic Chamber

Test Setup

Date of testing	: 2022-03-01 to 2022-03-08
Input voltage	: 24Vdc
Operation mode	: A
Ambient temperature	: 24.5~26.5 °C
Relative humidity	: 50~53 %
Atmospheric pressure	: 100~103 kPa

For the measurement records, refer to the appendix B.

5.1.3 Unwanted emissions

RESULT:**Pass****Test Specification**

Test standard	:	FCC Part 95.3379
Basic standard	:	ANSI C63.26: 2015, Clause 5.5 FCC Part 95.3379 (a)(1)
Limits	:	FCC Part 95.3379 (a)(2) FCC Part 95.3379 (a)(3)
Kind of test site	:	3m Semi-anechoic Chamber & 3m Full-anechoic Chamber

Test Setup

Date of testing	:	2022-03-01 to 2022-03-08
Input voltage	:	24Vdc
Operation mode	:	A
Ambient temperature	:	24.5~26.5 °C
Relative humidity	:	50~53 %
Atmospheric pressure	:	100~103 kPa

For the measurement records, refer to the appendix B.

5.1.4 Frequency stability

RESULT:**Pass****Test Specification**

Test standard	: FCC Part 95.3379 (b)
Basic standard	: ANSI C63.26: 2015, Clause 5.6
Limits	: Within assigned band (76GHz to 81GHz)
Kind of test site	: Temperature and Humidity Chamber

Test Setup

Date of testing	: 2022-03-01 to 2022-03-08
Input voltage	: 24Vdc
Operation mode	: A
Ambient temperature	: 20.1 °C
Relative humidity	: 53.7 %
Atmospheric pressure	: 100~103 kPa

For the measurement records, refer to the appendix B.

6 Safety Human Exposure

6.1 Radio Frequency Exposure Compliance

6.1.1 Electromagnetic Fields

RESULT:
Pass
Test Specification

Test standard : FCC CFR Title 47, Part 2, Subpart J, Section 2.1091
 Test limits : FCC CFR Title 47, Part 1, Subpart I, Section 1.1310

Limits for General Population/Uncontrolled Exposure

Frequency range (MHz)	Electric field strength (V/m)	Magnetic field strength (A/m)	Power density (mW/cm ²)	Averaging time (minutes)
0.3-1.34	614	1.63	*100	30
1.34-30	824/f	2.19/f	*180/f ²	30
30-300	27.5	0.073	0.2	30
300-1,500			f/1500	30
1,500-100,000			1.0	30

This device is mobile device, and the applicant declares that the minimum separation distance is greater than 20cm, detail minimum distance refer to below calculation table. Therefore MPE measurement or computational modeling should be used to determine compliance.

MPE Calculation is based on the conducted power, and considering maximum power and antenna gain. The following formula is used to MPE evaluation.

The power density according to far-field model is:

$$S = \frac{P \times G_{(\theta,\phi)}}{4 \times \pi \times R^2}$$

Where:

- P = input power of the antenna.
- G = antenna gain relative to an isotropic antenna.
- θ, ϕ = elevation and azimuth angles.
- R = distance from the antenna to the point of investigation.

Test Result:

Operation Frequency (GHz)	Maximum EIRP (dBm)	Maximum EIRP (mW)	Min. Distance (cm)	Calculation (mW/cm ²)	Limit (mW/cm ²)	Result
76.65	26.66	463.447	20	0.092	1	PASS

7 Photographs of the Test Set-Up

For photographs of the test set-up, refer to the appendix A.

8 List of Tables

Table 1 List of Test and Measurement Equipment.....	5
Table 2: Technical Specification of EUT.....	7
Table 3: Auxiliary Equipment Used during Test	8

Appendix B: Test Results

APPENDIX B: TEST RESULTS	1
APPENDIX B.1: OCCUPIED BANDWIDTH	2
APPENDIX B.2: RADIATED E.I.R.P. POWER	3
APPENDIX B.3: UNWANTED EMISSIONS	4
9kHz-30MHz	4
30MHz to 1GHz	8
1GHz to 40GHz	10
Above 40GHz	12
APPENDIX B.4: FREQUENCY STABILITY	14

Appendix B.1: Occupied Bandwidth

FL: 76.368GHz, FH: 76.924GHz
 Limit: Within assigned band (76GHz to 81GHz)

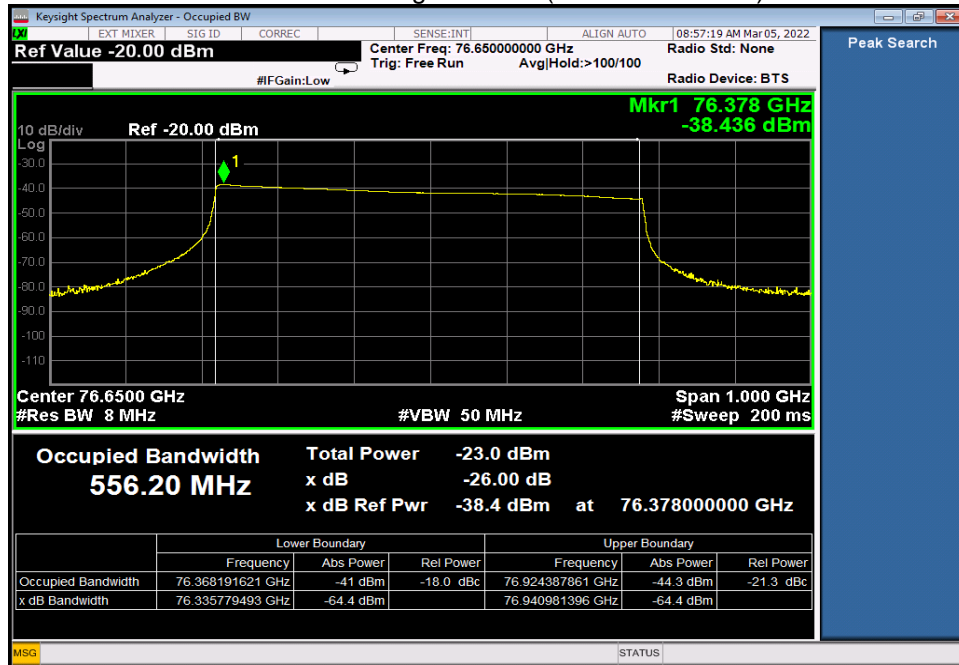

Appendix B.2: Radiated E.I.R.P. Power

Horizontal:

Frequency (GHz)	Measurement Distance (m)	EIRP (dBm)	EIRP Limit(dBm)
76.65	1	12.72	55 (Peak)
76.65	1	-9.87	50(Average)

Vertical:

Frequency (GHz)	Measurement Distance (m)	EIRP (dBm)	EIRP Limit(dBm)
76.65	1	26.66	55 (Peak)
76.65	1	7.29	50(Average)

Appendix B.3: Unwanted emissions

9kHz-30MHz



TUV Rheinland Taiwan Ltd.
 No. 458-18, Sec 2, Fenliao, Linkou Dist., New Taipei City 244, Taiwan(R.O.C.)
 Tel:+886-2172-1000 Fax:+886-2172-1322

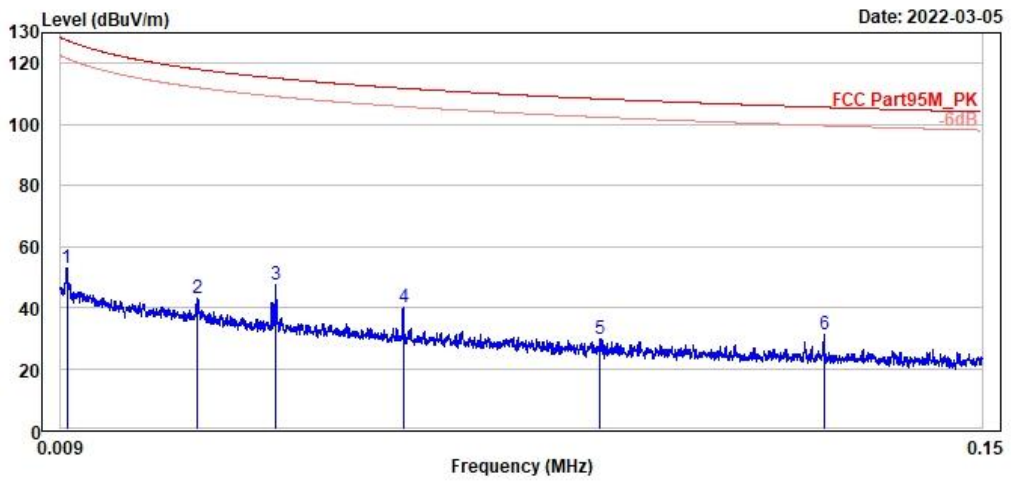

	Freq	Level	Read	Limit	Over	APos	TPos	Remark	Pol/Phase	Note
	MHz	dBuV/m	dBuV	dB/m	dBuV/m	dB	cm	deg		
1	0.01	53.00	35.26	17.74	127.60	-74.60	100	184 QP	Open	
2	0.03	42.78	23.23	19.55	118.04	-75.26	100	44 QP	Open	
3	0.04	47.31	27.88	19.43	115.14	-67.83	100	29 QP	Open	
4	0.06	40.25	21.15	19.10	111.83	-71.58	100	302 QP	Open	
5	0.09	29.58	11.14	18.44	108.36	-78.78	100	4 QP	Open	
6	0.13	30.91	12.56	18.35	105.60	-74.69	100	338 QP	Open	



TUV Rheinland Taiwan Ltd.
 No. 458-18, Sec 2, Fenliao, Linkou Dist., New Taipei City 244, Taiwan(R.O.C.)
 Tel:+886-2172-1000 Fax:+886-2172-1322

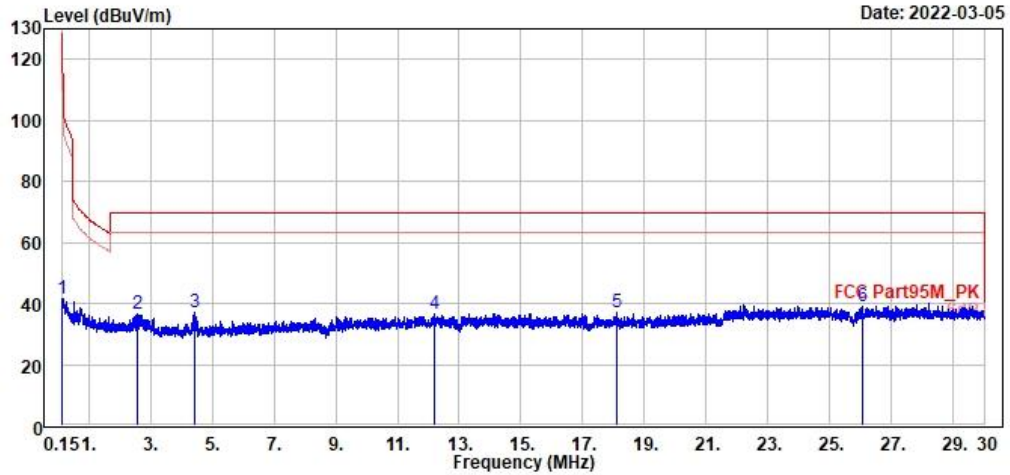

Date: 2022-03-05

	Freq	Level	Read	Limit	Over	APos	TPos	Remark	Pol/Phase	Note
	MHz	dBuV/m	dBuV	dB/m	dBuV/m	dB	cm	deg		
1	0.16	41.55	23.08	18.47	103.57	-62.02	100	28 QP	Open	
2	2.59	36.81	17.32	19.49	69.50	-32.69	100	134 QP	Open	
3	4.45	36.83	17.44	19.39	69.50	-32.67	100	330 QP	Open	
4	12.18	36.77	15.24	21.53	69.50	-32.73	100	165 QP	Open	
5	18.11	36.95	15.02	21.93	69.50	-32.55	100	230 QP	Open	
6	26.07	39.03	16.75	22.28	69.50	-30.47	100	113 QP	Open	



TUV Rheinland Taiwan Ltd.
 No. 458-18, Sec 2, Fenliao, Linkou Dist., New Taipei City 244, Taiwan(R.O.C.)
 Tel:+886-2172-1000 Fax:+886-2172-1322

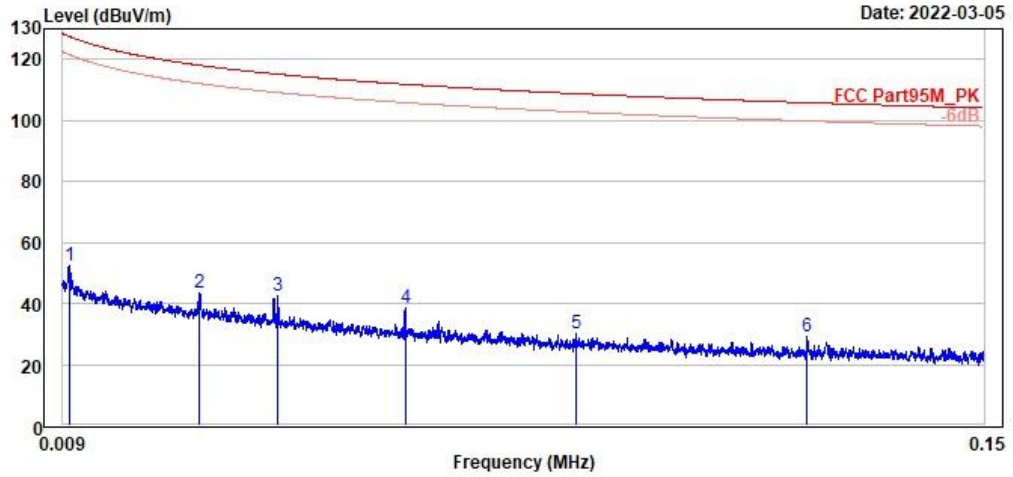

	Freq	Level	Read	Limit	Over	APos	TPos	Remark	Pol/Phase	Note
	MHz	dBuV/m	dBuV	dB/m	dBuV/m	dB	cm	deg		
1	0.01	52.51	34.76	17.75	127.52	-75.01	100	360 QP	Close	
2	0.03	43.56	24.01	19.55	118.05	-74.49	100	270 QP	Close	
3	0.04	42.62	23.19	19.43	115.14	-72.52	100	157 QP	Close	
4	0.06	38.62	19.52	19.10	111.82	-73.20	100	48 QP	Close	
5	0.09	30.04	11.51	18.53	108.75	-78.71	100	73 QP	Close	
6	0.12	29.00	10.66	18.34	105.81	-76.81	100	265 QP	Close	



TUV Rheinland Taiwan Ltd.
 No. 458-18, Sec 2, Fenliao, Linkou Dist., New Taipei City 244, Taiwan(R.O.C.)
 Tel:+886-2172-1000 Fax:+886-2172-1322

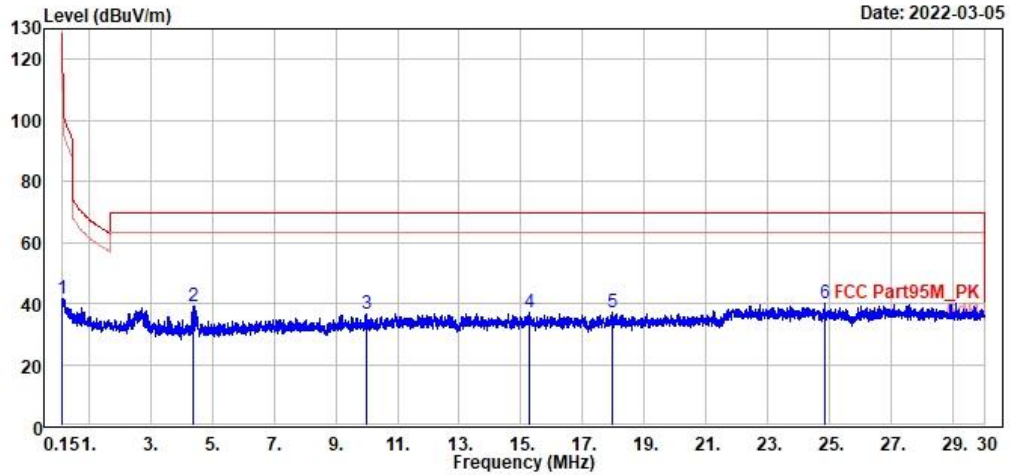

	Freq	Level	Read Level	Factor	Limit Line	Over Limit	APos	TPos	Remark	Pol/Phase	Note
	MHz	dBuV/m	dBuV	dB/m	dBuV/m	dB	cm	deg			
1	0.15	41.50	23.06	18.44	104.08	-62.58	100	101	QP	Close	
2	4.41	39.08	19.68	19.40	69.50	-30.42	100	181	QP	Close	
3	9.98	36.67	15.30	21.37	69.50	-32.83	100	301	QP	Close	
4	15.28	37.06	15.32	21.74	69.50	-32.44	100	312	QP	Close	
5	17.95	37.01	15.09	21.92	69.50	-32.49	100	96	QP	Close	
6	24.83	40.00	17.77	22.23	69.50	-29.50	100	92	QP	Close	

30MHz to 1GHz



TUV Rheinland Taiwan Ltd.
 No. 458-18, Sec 2, Fenliao, Linkou Dist., New Taipei City 244, Taiwan(R.O.C.)
 Tel:+886-2172-1000 Fax:+886-2172-1322

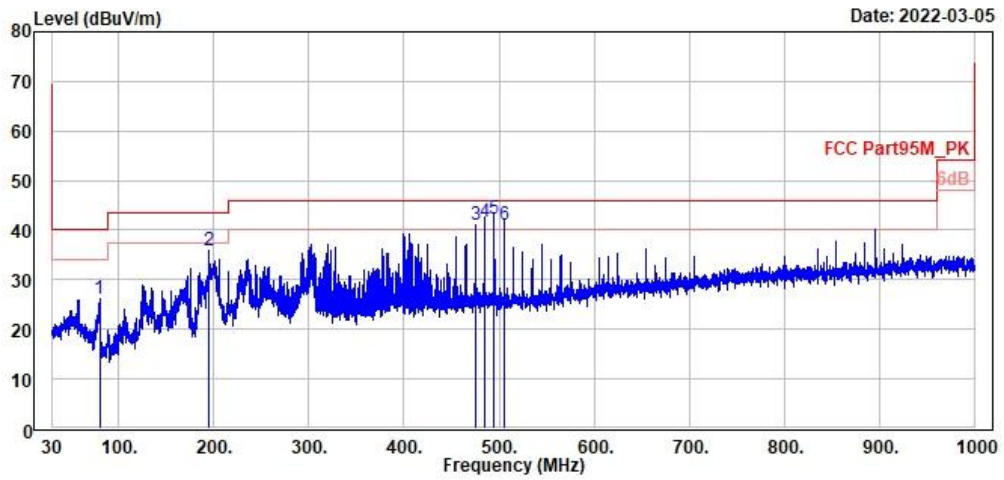

	Freq	Level	Read Level	Factor	Limit Line	Over Limit	APos	TPos	Remark	Pol/Phase	Note
	MHz	dBuV/m	dBuV	dB/m	dBuV/m	dB	cm	deg			
1	79.66	26.13	37.71	-11.58	40.00	-13.87	300	144	QP	Horizontal	
2	194.90	35.84	45.19	-9.35	43.50	-7.66	385	175	QP	Horizontal	
3 !	475.04	40.98	43.60	-2.62	46.00	-5.02	199	253	QP	Horizontal	
4 !	484.93	41.63	44.11	-2.48	46.00	-4.37	200	284	QP	Horizontal	
5 !	495.02	42.39	44.82	-2.43	46.00	-3.61	200	258	QP	Horizontal	
6 !	504.91	41.15	43.40	-2.25	46.00	-4.85	198	297	QP	Horizontal	



TUV Rheinland Taiwan Ltd.
 No. 458-18, Sec 2, Fenliao, Linkou Dist., New Taipei City 244, Taiwan(R.O.C.)
 Tel:+886-2172-1000 Fax:+886-2172-1322

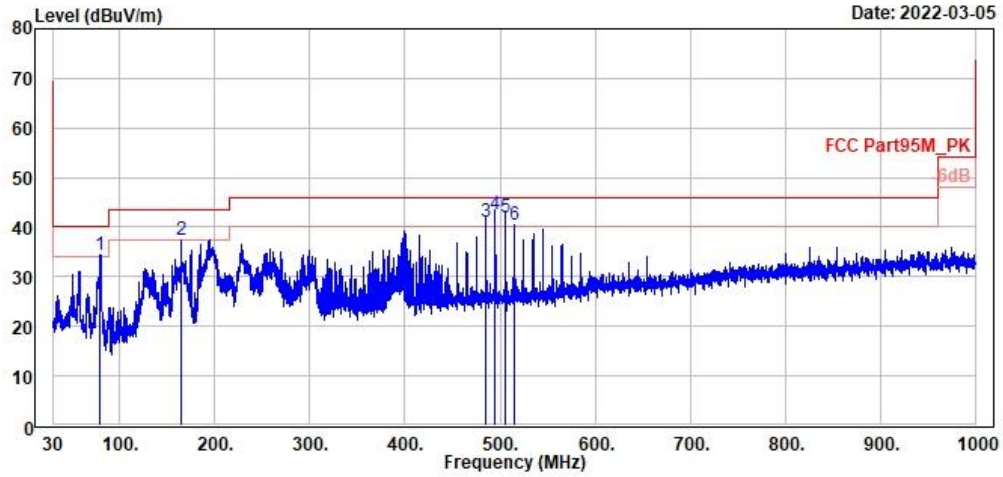

Date: 2022-03-05

	Freq	Level	Read Level	Factor	Limit Line	Over Limit	APos	TPos	Remark	Pol/Phase	Note
	MHz	dBuV/m	dBuV	dB/m	dBuV/m	dB	cm	deg			
1 !	79.47	34.31	45.85	-11.54	40.00	-5.69	200	341	QP	Vertical	
2 !	165.02	37.55	44.22	-6.67	43.50	-5.95	102	28	QP	Vertical	
3 !	484.93	41.12	43.60	-2.48	46.00	-4.88	107	56	QP	Vertical	
4 !	495.02	42.44	44.87	-2.43	46.00	-3.56	102	304	QP	Vertical	
5 !	504.91	41.88	44.13	-2.25	46.00	-4.12	100	68	QP	Vertical	
6 !	515.10	40.40	42.56	-2.16	46.00	-5.60	100	59	QP	Vertical	

1GHz to 40GHz



TUV Rheinland Taiwan Ltd.
 No. 458-18, Sec 2, Fenliao, Linkou Dist., New Taipei City 244, Taiwan(R.O.C.)
 Tel:+886-2172-1000 Fax:+886-2172-1322

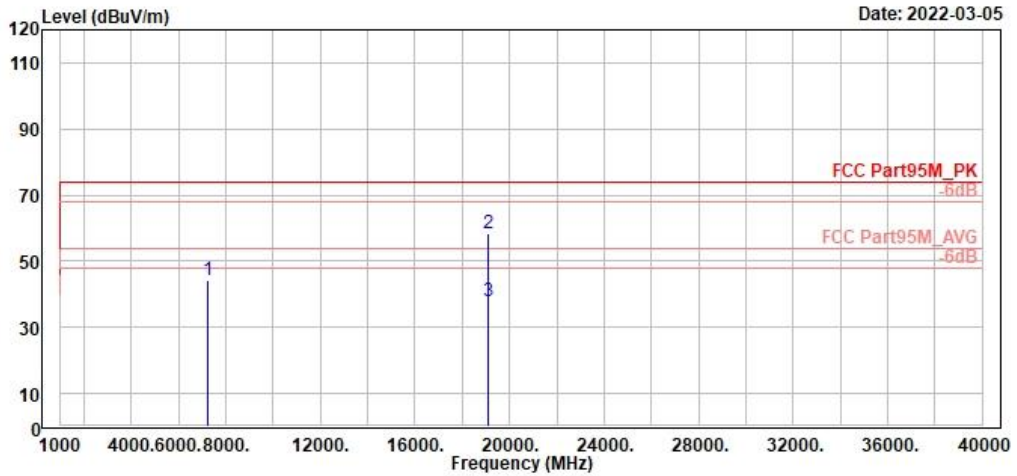

	Freq	Level	Read Level	Factor	Limit Line	Over Limit	APos	TPos	Remark	Pol/Phase	Note
	MHz	dBuV/m	dBuV	dB/m	dBuV/m	dB	cm	deg			
1	7266.00	44.09	51.48	-7.39	74.00	-29.91	400	184	Peak	Horizontal	
2	19089.48	58.37	60.24	-1.87	74.00	-15.63	200	353	Peak	Horizontal	
3	19089.48	37.79	39.66	-1.87	54.00	-16.21	200	353	Average	Horizontal	



TUV Rheinland Taiwan Ltd.
 No. 458-18, Sec 2, Fenliao, Linkou Dist., New Taipei City 244, Taiwan(R.O.C.)
 Tel:+886-2172-1000 Fax:+886-2172-1322

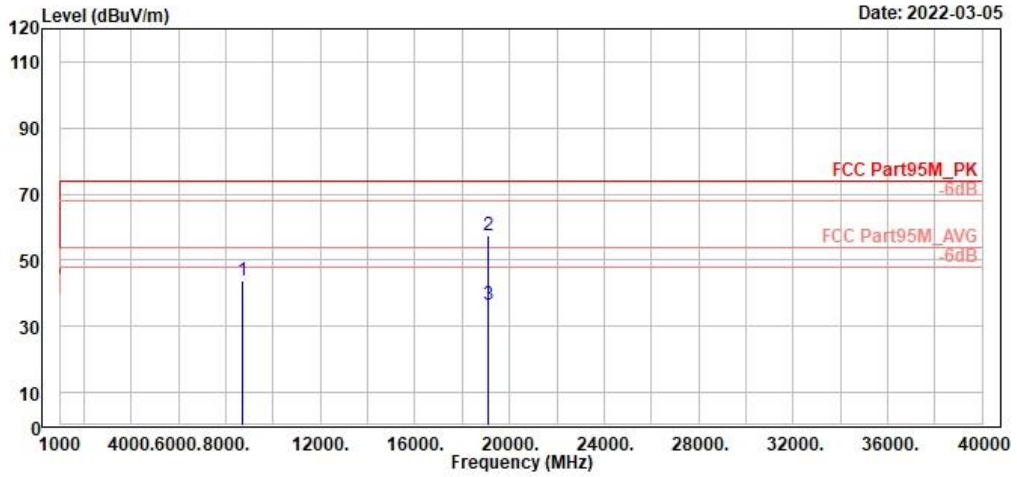

	Freq	Level	Read Level	Factor	Limit Line	Over Limit	APos	TPos	Remark	Pol/Phase	Note
	MHz	dBuV/m	dBuV	dB/m	dBuV/m	dB	cm	deg			
1	8704.00	43.74	49.90	-6.16	74.00	-30.26	268	360	Peak	Vertical	
2	19089.48	57.41	59.28	-1.87	74.00	-16.59	200	286	Peak	Vertical	
3	19089.48	36.56	38.43	-1.87	54.00	-17.44	200	286	Average	Vertical	

Above 40GHz

TX_40G~50G_H				
Frequency (GHz)	Measurement Distance (m)	Cal. Measurement Distance (1m to 3m) Level Power Density (W/cm ²)	Power Density (pW/cm ²)	Limit@3m (pW/cm ²)
44.98	1	0.000000001	0.13	600

TX_40G~50G_V				
Frequency (GHz)	Measurement Distance (m)	Cal. Measurement Distance (1m to 3m) Level Power Density (W/cm ²)	Power Density (pW/cm ²)	Limit@3m (pW/cm ²)
45.33	1	0.000000001	0.14	600

TX_50G~75G_H				
Frequency (GHz)	Measurement Distance (m)	Cal. Measurement Distance (1m to 3m) Level Power Density (W/cm ²)	Power Density (pW/cm ²)	Limit@3m (pW/cm ²)
55.30	1	0.000000000	0.02	600

TX_50G~75G_V				
Frequency (GHz)	Measurement Distance (m)	Cal. Measurement Distance (1m to 3m) Level Power Density (W/cm ²)	Power Density (pW/cm ²)	Limit@3m (pW/cm ²)
58.175	1	0.000000000	0.03	600

TX_75G~110G_H				
Frequency (GHz)	Measurement Distance (m)	Cal. Measurement Distance (1m to 3m) Level Power Density (W/cm ²)	Power Density (pW/cm ²)	Limit@3m (pW/cm ²)
83.621	1	0.000000011	1.07	600

TX_75G~110G_V				
Frequency (GHz)	Measurement Distance (m)	Cal. Measurement Distance (1m to 3m) Level Power Density (W/cm ²)	Power Density (pW/cm ²)	Limit@3m (pW/cm ²)
83.54	1	0.000000076	7.62	600

TX_110G~140G_H				
Frequency (GHz)	Measurement Distance (m)	Cal. Measurement Distance (1m to 3m) Level Power Density (W/cm ²)	Power Density (pW/cm ²)	Limit@3m (pW/cm ²)
123.98	1	0.000000001	0.13	600
TX_110G~140G_V				
Frequency (GHz)	Measurement Distance (m)	Cal. Measurement Distance (1m to 3m) Level Power Density (W/cm ²)	Power Density (pW/cm ²)	Limit@3m (pW/cm ²)
119.72	1	0.000000001	0.12	600
TX_140G~231G_H				
Frequency (GHz)	Measurement Distance (m)	Cal. Measurement Distance (1m to 3m) Level Power Density (W/cm ²)	Power Density (pW/cm ²)	Limit@3m (pW/cm ²)
140.29	1	0.000000002	0.18	600
TX_140G~231G_V				
Frequency (GHz)	Measurement Distance (m)	Cal. Measurement Distance (1m to 3m) Level Power Density (W/cm ²)	Power Density (pW/cm ²)	Limit@3m (pW/cm ²)
140.18	1	0.000000002	0.19	600

Appendix B.4: Frequency stability

Test Temperature (°C)	Test Voltage (Vdc)	Measured Frequency (MHz)	Operating Frequency (MHz)	Limit (Within 76GHz to 81GHz)
-20	24	76407.5678	76650	Within assigned band
-10	24	76408.9204		
0	24	76412.9713		
10	24	76415.4342		
20	24	76433.9865		
30	24	76420.7452		
40	24	76416.5469		
50	24	76410.3589		
Test Temperature (°C)	Test Voltage (Vdc)	Measured Frequency (GHz)		
20	27.6	76422.4096	76650	Within assigned band
20	24	76436.2184		
20	20.4	76413.7995		